



March 3, 2023

Tatiana Kaseta  
105 Meadow Spring Ln.  
Sanford, NC 27332  
Email: [tatiana@tsdesignnc.com](mailto:tatiana@tsdesignnc.com)

Reference: Engineering Services  
105 Meadow Spring Ln.  
Sanford, NC 27332  
TE&D Project No.: 2301-020195

To Whom It May Concern;

As requested by the builder, a representative of Tyndall Engineering & Design, PA (TE&D) was on-site to observe the following items:

- 1) The exterior walls of the sunroom addition do not comply with the portal framing requirements of the 2018 NC Residential Building Code.
- 2) The 2 x 8 joists were notched to bear on the LVL beam.

The following conclusions and recommendations were noted:

- 1) The exterior walls of the sunroom are to be modified with the following:
  - a. The bottom sill plate of the back wall is to be fastened to the rimboard with 6" long Fastenmaster Timberlok screws installed at 16" o.c. Screws are to be driven as vertically as possible into the rimboard below.
  - b. Additional stud columns are to be packed tightly into open space between the windows and the corners.
  - c. The interior of all exterior walls is to be covered with 5/8" structural sheathing. Sheathing is to be secured to all studs and headers with 8D nails at 8" o.c.
  - d. The back exterior corners of the sunroom are to be secured to the foundation with (1) Simpson FJA anchor (or equivalent) installed per the manufacturer's specifications in each corner. Anchors are to be fastened to the last joist at each foundation corner.
- 2) The existing 2 x 8 ceiling joists at 16" o.c. were notched approximately 1-1/2" to bear on the LVL beam. Based on our observations and analysis, this configuration is inadequate to support the anticipated loading conditions. New 2 x 8 x 1'-0" scabs are to be secured with a minimum (4) 10D nails to the notched end. New scabs are to be notched and have full bearing on the LVL beam below.



Upon completion, the modified framing listed above will provide the required support for the anticipated loading conditions. We appreciate being able to assist you during this phase of the project. If you need further assistance or require additional information, please do not hesitate to contact us.

Sincerely,  
Tyndall Engineering & Design

Tripp Amos  
BH | 2301-020195

Alan W. Lewis, P.E.

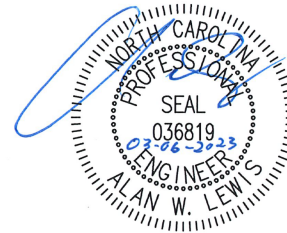



Item 1.a. Install Fastenmaster screws at the rim board



Item 1.b. Install additional 2 x 4 studs packed tightly to corners





Item 1.c. Sheath the interior of all exterior walls



Item 1.d. Install Simpson FJA anchors at the exterior corners.

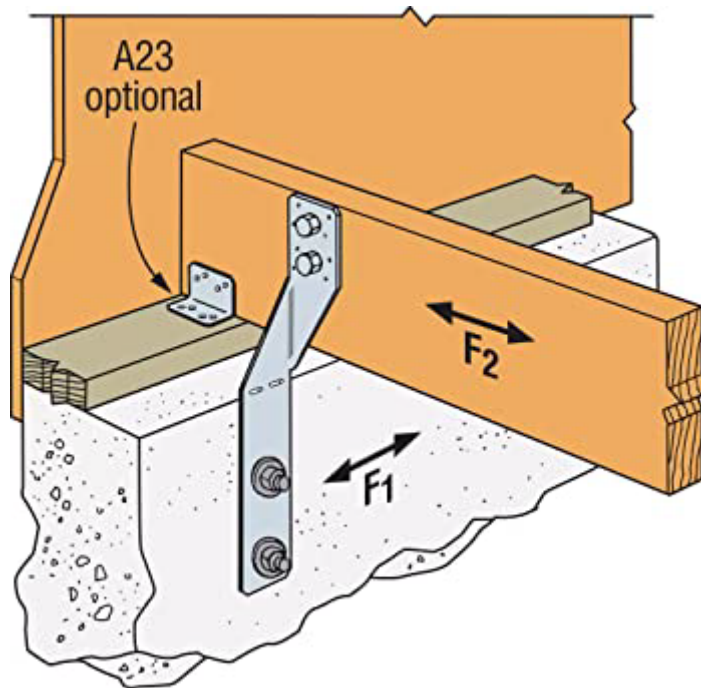

(image obtained from Simpson catalog)



Item 2. Install 2 x 8 x 1' scabs for addition bearing.

